

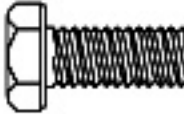









COMPONENTS

REF. #	QTY.	DESCRIPTION
1	2	BASE ANGLE WELDMENT
2	4	CORNER/RACK MOUNT RAIL
3	4	DEPTH ADJ. CROSS CHANNEL
4	2	TOP BRACE

HARDWARE BAG

REF. #	QTY.	DESCRIPTION		
E1	22	Screw, 5/16-18 X 3/4		
E2	16	Washer, 5/16		
E3	22	Nut, Keps 5/16-18		
E4	12	Washer 5/16		
E5	32	SCREW 1/4-20 x 3/4		
E6	32	Nut, Keps 1/4-20		

STEP 1

Attach Top Brace (4) to Rack Mount Rail (2) using Screws (E1), Washers (E2) and Nuts (E3). See Fig. 1

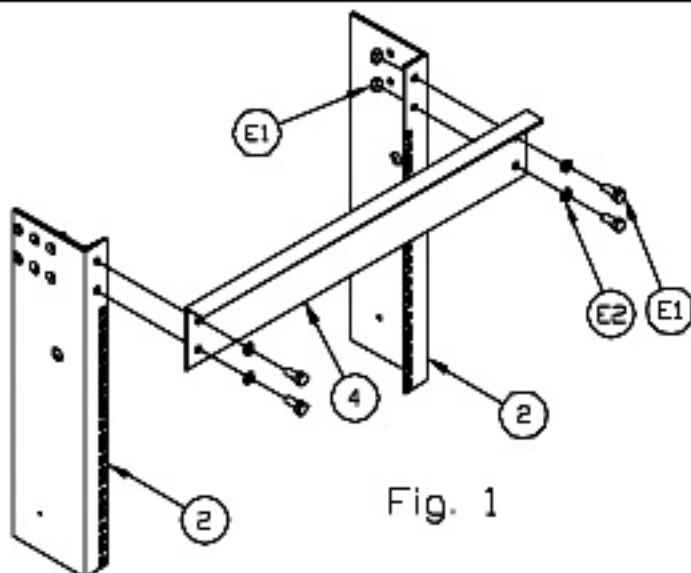

Rackit®
Technology Corporation

1.800.636.3434
www.RackitTechnology.com

■ STEP 7

(Mounting Rack to floor)

To support the Maximum 1500 lbs. load rating requires the Rack to be anchored to the floor before loading with equipment. Place the Rack in the desired location and mark the floor mounting hole locations onto the floor. See Fig. 5 for mounting hole location. Use the recommended hardware shown below dependent upon floor style.

Fig. 5

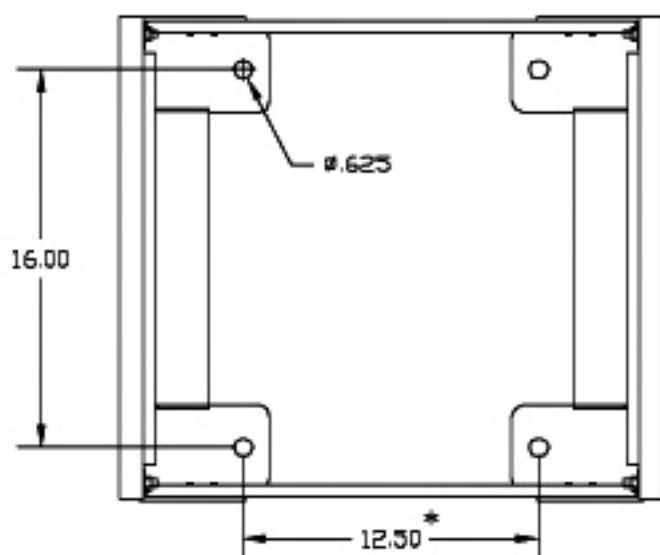

* BASE ADJUSTABLE IN 1/2" INCREMENTS
UP TO 17.50 IN (21-26) DEPTH
UP TO 21.50 IN (27-32) DEPTH

HARDWARE RECOMMENDATIONS

(Not Supplied)

A. Wood Floor

QTY.	DESCRIPTION
4	3/8-7 x 2" Hex Head Lag Screw
4	3/8 Split Lock Washer
4	3/8 Fender Washer

B. Concrete Floor

QTY.	DESCRIPTION
4	3/8-16 Concrete Anchors
4	3/8-16 x 3 1/2" Studs
4	3/8-16 Hex Nuts
4	3/8 Split Lock Washers
4	3/8 Fender Washers

Rackit[®]
Technology Corporation

1.800.636.3434
www.RackitTechnology.com

■ STEP 6

(Attaching additional Racks)

Attach Racks using Screws (E1), Washers (E4) and Nuts (E3).
(6 Places) See Fig. 4.

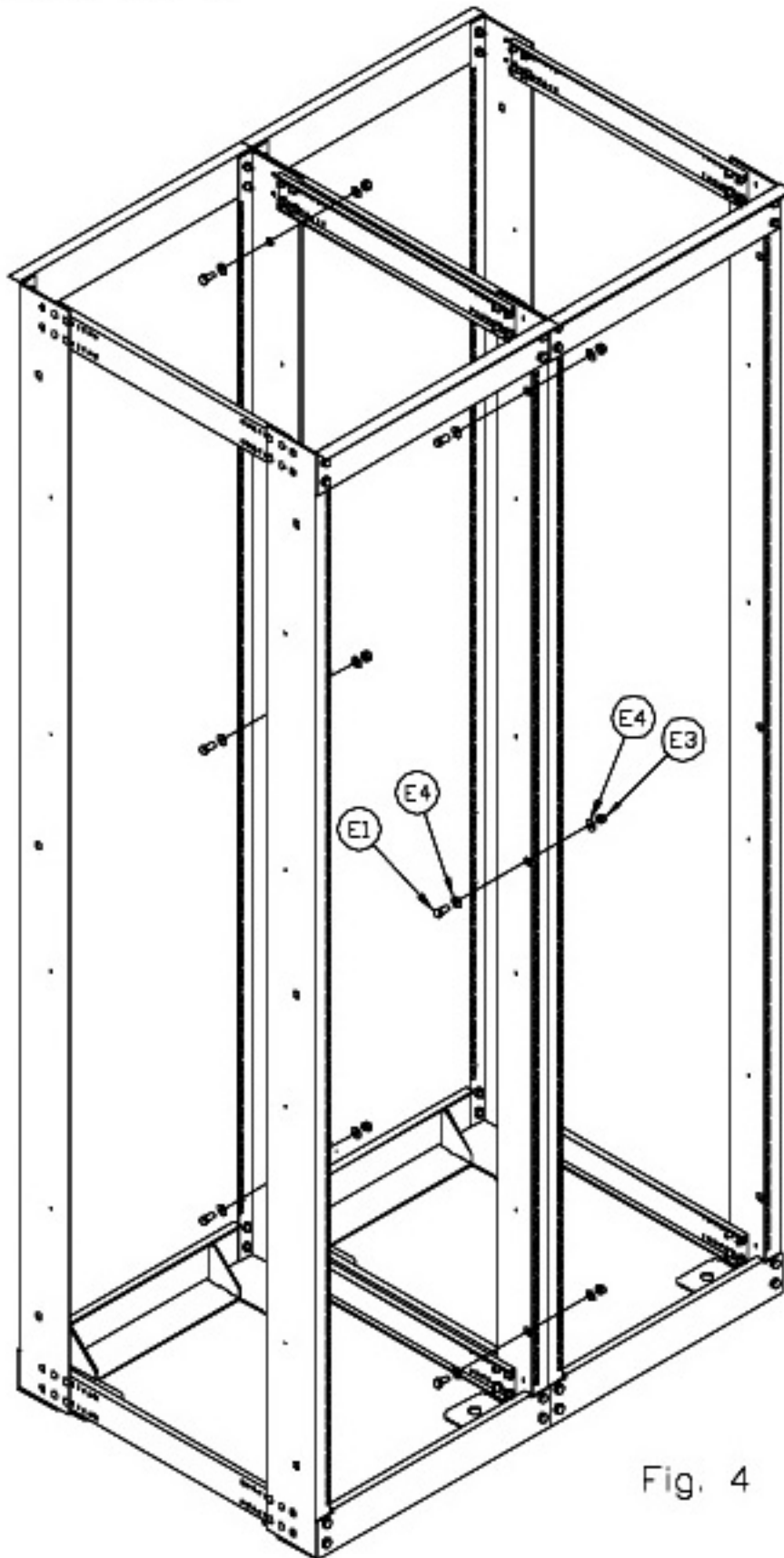

Fig. 4

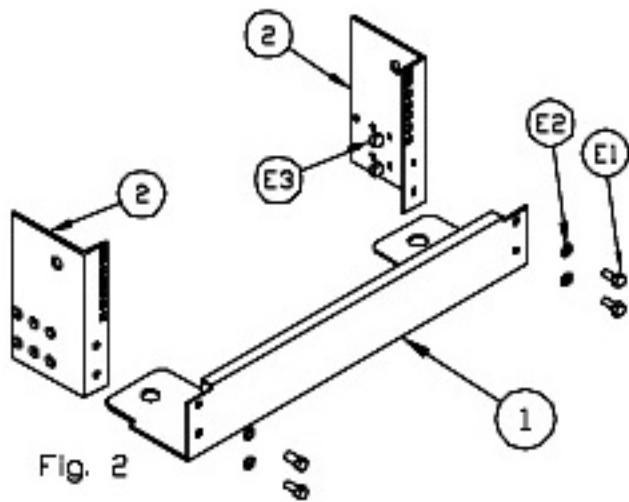

Fig. 2

■ **STEP 2**

Attach Base Angle Weldment (1) to Rack Mount Rail (2) using Screws (E1), Washers (E2) and Nuts (E3). See Fig. 2

NOTE: Base Angle Weldment (1) installs as shown to reduce foot print. Angle may be installed in opposite direction to have mounting holes for anchoring on outside of frame.

■ **STEP 3**

Repeat steps 1 & 2 for opposite side of rack.

■ **STEP 4**

Attach Adjustable Cross Channel (3) & Frame Assembly to desired depth using Screws (E5) and Nuts (E6). See Fig. 3 & (E3A). (E6)

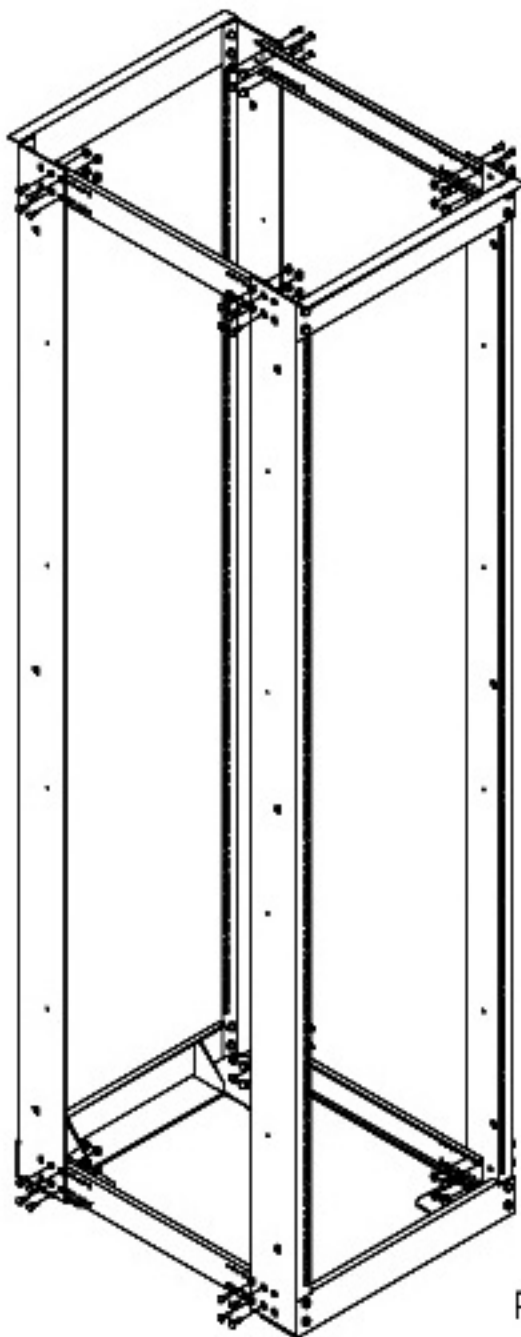

Fig. 3

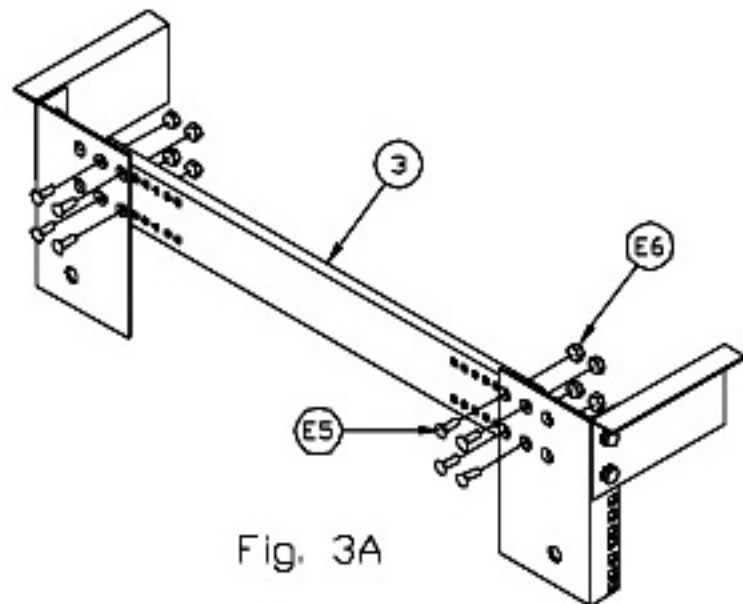

Fig. 3A

■ **STEP 5**

(Adjusting rack after assy.)
To adjust depth of 11 rack remove Screws (E5), Nuts (E6) and Cross Channel (3) & Re-install at desired depth. See Fig 3 & 3A