

Bill of Material				
ITEM	PART NUMBER	QTY	DESCRIPTION	
		2	POWER STRIP BRACKET	
2		2	SPRING CLIP-ON MOUNTING BRACKETS	
3			M6 CAGE NUT	
4		2	#10-32 x 1/4" L FLAT HEAD PHIL SCREW, TYPE 23	
5			#12-24 x 1/2" L PAN HEAD PHIL TYPE 23 SCREW	
6			M6 x 12mm PAN HEAD ZN PL SCREW	

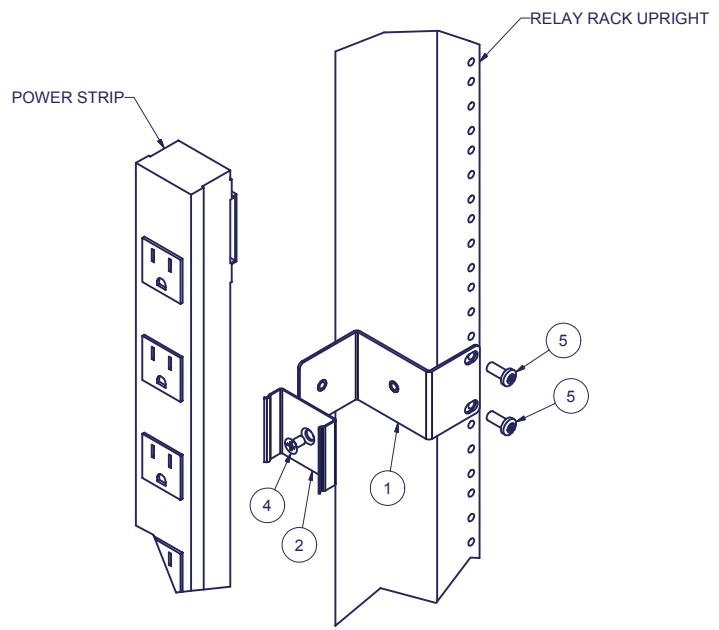
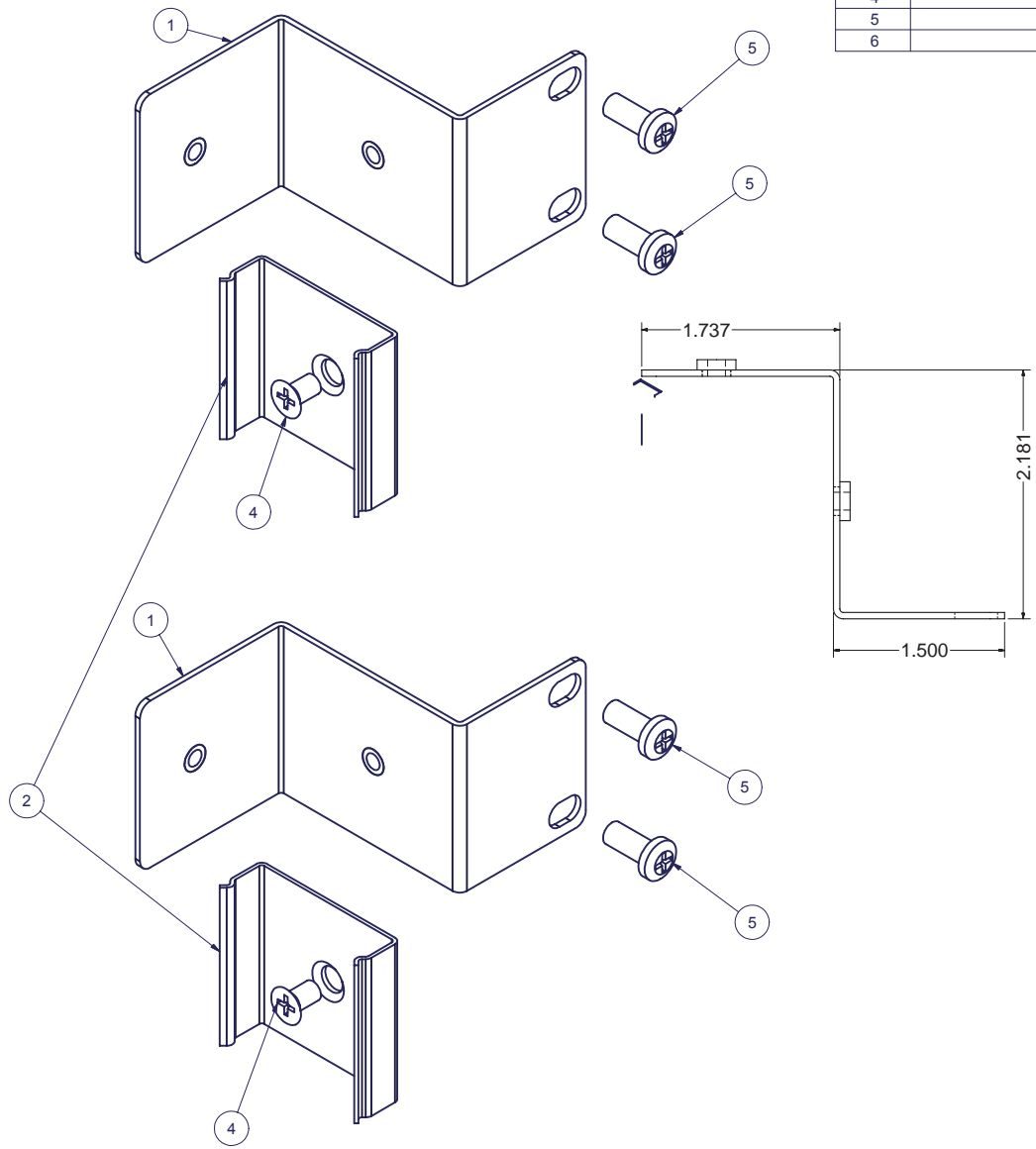

DETAIL A  
FOR TAPPED #12-24 UPRIGHT  
(M6 HARDWARE USED FOR M6 UPRIGHT)

## Zero-U Open-Rack PDU

# Assemble•it™ Instructions

**Rackit**®  
Technology Corporation

274 Madison Avenue, New York, NY 10016  
Tel: 212-679-0050 • Fax: 212-679-0040  
E-mail: Rackit@RackitTechnology.com

1.800.636.3434  
[www.RackitTechnology.com](http://www.RackitTechnology.com)